



DYNOPTIC

DSL-230

Single Pass Opacity Monitor

Measures 0-1000mg/m³



Ideal for monitoring smoke and particulate concentrations in the exhaust gas of industrial combustion or air filtration processes.

Applications

- Boilers
- Diesel Engines
- Wood Burners
- Incinerators
- Crematoria
- Electrostatic Precipitators
- Filter Bag Houses
- Combustion Furnaces

Benefits

- Low cost, low maintenance (no moving parts & easy optics access)
- Simple installation, commissioning, and operation
- Alarm level contact, 4-20mA loop, ModBus comms, and USB header
- Free utility software for PC based setup, control, and data logging
- Stand-alone version available (no control unit - just measuring heads)
- Choice of control unit enclosures (external IP65, panel, or rack)
- Choice of 24VDC or 90-260VAC ; optional stainless steel heads

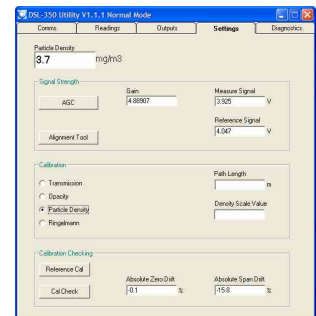

The DSL-230 is an optical instrument designed to measure the concentration of dust or particulate matter suspended in exhaust gas passing through a duct, stack, or flue - typically the exhaust gas from an industrial combustion process or air filtration system.

The DSL-230 uses the standard single pass transmission measurement technique (transmitter/receiver arrangement) in which a light beam emitted from the transmitter passes across the stack to a receiver, which then measures the intensity of the received light. Increased particulate or smoke density in the stack gas attenuates the transmitted light and causes the intensity of the received light to fall. When calibrated against standard reference measurements, this reduction in intensity can be used to calculate the particulate concentration and present a reading in mg/m³.

The light source in the transmitter is a high intensity, high reliability green LED which provides long life and stable intensity. The transmitted light beam is pulsed to give complete immunity to ambient light levels. The intensity of the transmitted light is monitored at source so that any variations in the emitted light level are compensated for at the receiver. The receiver has on board temperature measuring to provide stability over temperature.

The DSL-230 is available with or without an Operator Interface (control unit), so for the most cost effective monitoring solution the DSL-230 can operate as a "stand-alone" head pair consisting of just the transmitter head (TX) and receiver head (RX), with all electrical connections (including outputs such as the alarm relays, 4-20mA, and ModBus) being made inside the RX head. As a stand-alone instrument the DSL-230 is set-up and controlled using the supplied utility software, installed on a PC or laptop, and connected via the USB connector on the RX.

When supplied with an Operator Interface (OI) all power supply and output connections are made in the OI rather than the RX. The OI is available in either an IP65 rated wall mounting enclosure (for outdoor use), as a small panel (for installation in larger system panels), or as a rack panel (for installation in standard rack cabinets). The OI itself has a bright 4 digit LED display and a simple 4 button keypad which allow full command and control of the instrument. Alternatively, the free utility software can be connected to the OI and used to command and control the DSL-230 directly from a PC.

The DSL-230 has no moving parts, is of rugged design, and has an excellent reliability record. Regular maintenance simply involves cleaning the TX and RX lenses, which are easily accessible due to our latched head design. Both the TX and RX are supplied with an air purge body which when connected to a high volume source of clean air (a blower is recommended) will resist particle deposition on the lenses and further lengthen service intervals.



Dynoptic Systems Ltd, Furlong House, Crowfield, Brackley, Northamptonshire NN13 5TW United Kingdom
Telephone: +44 (0)1280 850521, Facsimile: +44 (0)1280 850568
Email: contact@dynoptic.com, Web site: www.dynoptic.com



© Dynoptic Systems Ltd
02/04/2009 V1.2

All technical details and specifications are subject to change without notice



DYNOPTIC

DSL-230

Single Pass Opacity Monitor

Measures 0-1000mg/m³

Specification:

Measurement Performance

No.	Parameter	Units	Min	Max	Comment
1	Path Length (flange to flange)	m	0.5	20	Flange-to-flange separation
2	Measuring Range	mg/m ³	0.0	1000.0	User selectable
3	Accuracy	%	-2	+2	Relative to the maximum range
4	Resolution	mg/m ³		0.1	Display resolution
5	Damping	s	1	60	Selectable
6	Drift with Temperature	%	-2	+2	Over any 20°C in the operating range
7	Operating Wavelength	nm	510	540	Green LED

Power & Air Requirements

8	Voltage	VDC	+24	+24	Optional 90-260VAC PSU available
9	Voltage Tolerance	%	-10	+10	
10	Nominal Current Consumption	mA		400	
11	Power Up Current Consumption	mA		400	
12	Air Supply Volume	m ³ /h	5	60	Optimum: 40m ³ /h
13	Air Supply Pressure	mbar		500	Must exceed maximum stack pressure
14	Air Supply Fitting				1" BSP threaded aperture in each Air-Purge Head

Cable and Wire

15	Cable type – TX/RX Interconnection	cores	6		Screened multi-core, such as Belden 9874
16	Cable type – OI/RX Interconnection	cores	4		Screened multi-core, such as Belden 9874
17	Wire Size at Terminal Connections	AWG	28	14	

Interface Options

18	Serial Comms				1. ModBus RTU (on terminals in OI or TRX) 2. Internal USB (OI), external USB (RX) 3. ProfiBus, DeviceNet, Ethernet etc. on request
19	Analogue Outputs	mA	4.0	20.0	Isolated and scalable
20	Relay Contacts	A	0	3	@30VDC (level alarm and service alarm)

Physical

21	Ingress Protection - TX/RX Heads		IP65		For external use
22	Ingress Protection – OI Wall Mounting – OI Panel Mounting – OI Rack Mounting		IP65 IP64 IP50		Hinged door and terminal compartment shut From front face of panel when installed
23	Operating Humidity	%	5	100	
24	Ambient Operating Temperature	°C	-20	+50	Air temperature around the equipment
25	Gas Temperature	°C		+600	Optional insulators required above 300°C
26	Regulatory Compliance				89/336/EEC (Electromagnetic Radiation) 73/23/EEC (Low Voltage)
27	Materials – TX/RX Heads				Anodised and powder coated cast aluminium air-purge bodies, with polycarbonate measurement head, and stainless steel latches
28	Materials – OI Wall Mounting – OI Panel Mounting – OI Rack Mounting				Aluminium front panel with PU laminate overlay, and PC enclosure with nylon cable glands Aluminium front panel with PU laminate overlay, and powder coated steel back-box with nylon cable glands Aluminium front panel with PU laminate overlay, and powder coated steel back-box with nylon cable glands
29	Warranty	months	24		Return to base warranty



Dynoptic Systems Ltd, Furlong House, Crowfield, Brackley, Northamptonshire NN13 5TW United Kingdom
 Telephone: +44 (0)1280 850521, Facsimile: +44 (0)1280 850568
 Email: contact@dynoptic.com, Web site: www.dynoptic.com



© Dynoptic Systems Ltd
02/04/2009 V1.2

All technical details and specifications are subject to change without notice



DSL-230

Single Pass Opacity Monitor
Measures 0-1000mg/m³

Configuration Options:

Configured with an
OI: Wall, Panel, or
Rack Mounting

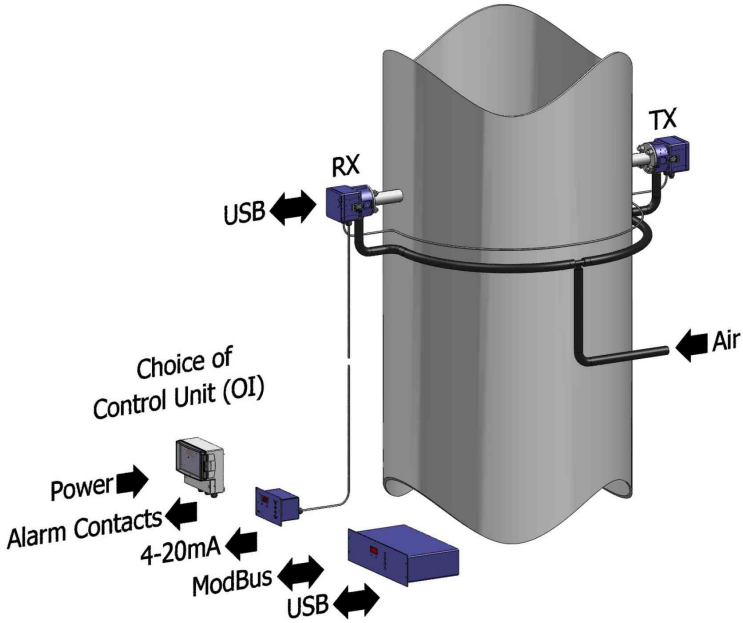

OR

Stand Alone
Configuration

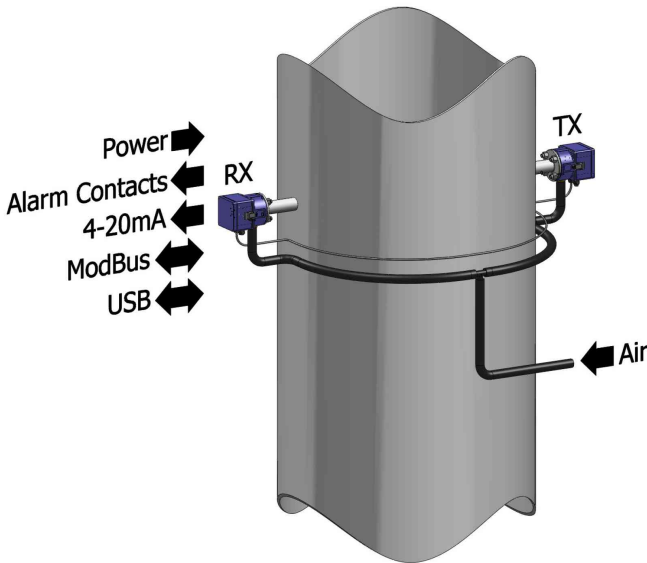



DYNOPTIC

DSL-230

Single Pass Opacity Monitor
Measures 0-1000mg/m³

Dimensions:

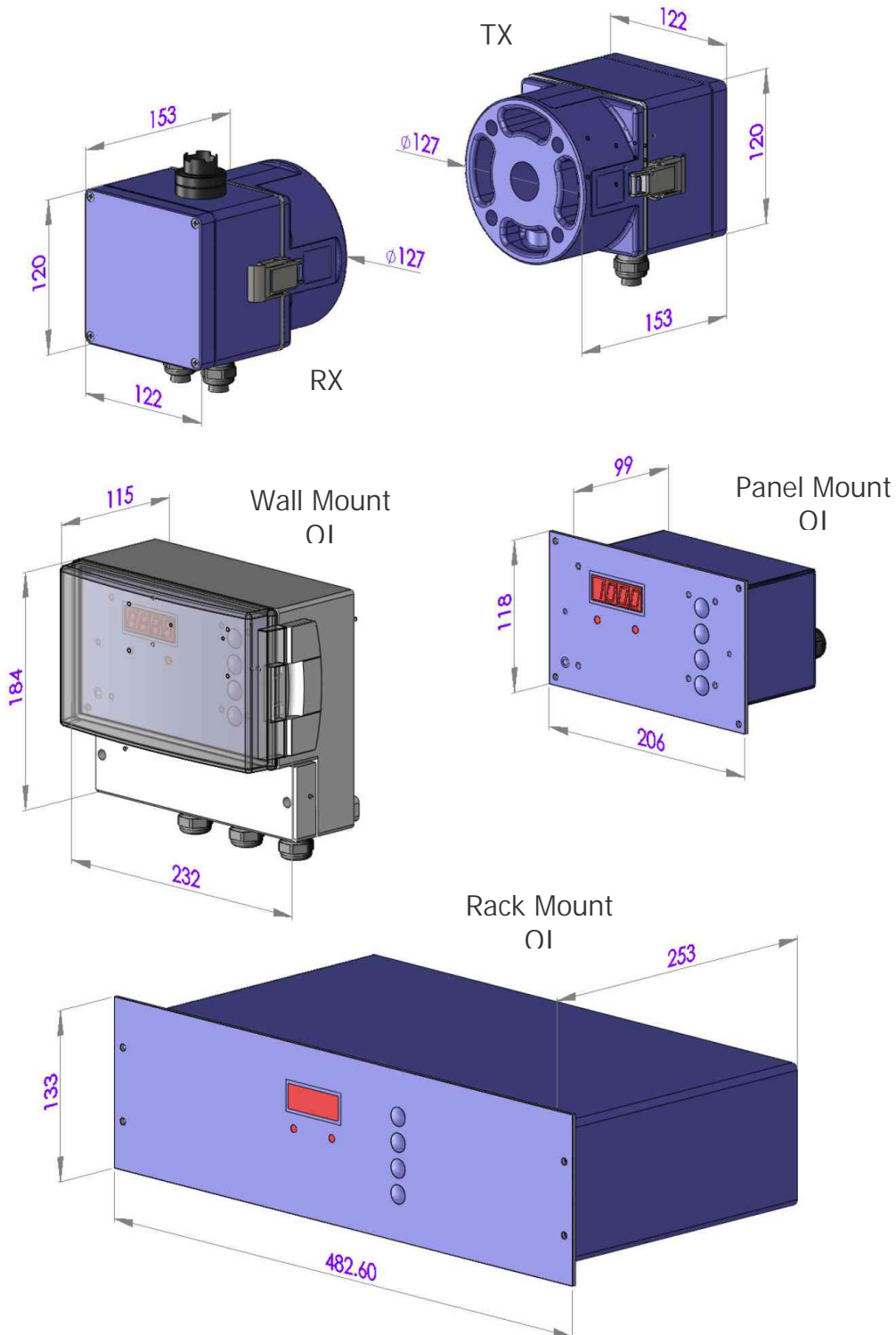

Dynoptic Systems Ltd, Furlong House, Crowfield, Brackley, Northamptonshire NN13 5TW United Kingdom
 Telephone: +44 (0)1280 850521, Facsimile: +44 (0)1280 850568
 Email: contact@dynoptic.com, Web site: www.dynoptic.com



© Dynoptic Systems Ltd
02/04/2009 V1.2

All technical details and specifications are subject to change without notice



DSL-230

Single Pass Opacity Monitor
Measures 0-1000mg/m³

Ordering Details:

DSL-230 X X X X

A = Aluminium air-purge heads
S = Stainless steel air-purge heads

D = 24VDC powered
A = 90-260VAC powered

N = No OI
W = Wall mounted OI
P = Panel mounted OI
R = Rack mounted OI

S = Short path length version (0.5 - 5m flange to flange separation)
L = Long path length version (3 - 20m flange to flange separation)



Dynoptic Systems Ltd, Furlong House, Crowfield, Brackley, Northamptonshire NN13 5TW United Kingdom
Telephone: +44 (0)1280 850521, Facsimile: +44 (0)1280 850568
Email: contact@dynoptic.com, Web site: www.dynoptic.com

